

# Bellows - EPDM - Flanged PN16

LV 9860

Flanged **PN16**, EPDM Bellows, Zinc Plated Steel Flanges



Pressure / Temperature Specifications	
Pressure	PN16
Temperature	-10°C to 100°C

Material Specifications	
Bellow	EPDM
Flanges	Zinc Plated Carbon Steel

Dimensions										
Size	2"	2½"	3"	4"	5"	6"	8"	10"	12"	
L	130	130	130	130	130	130	130	130	130	130
Tolerance Installed (Min/Max)	-----				122 - 133	-----				
Ac (See diagram)	30	30	30	30	30	30	30	30	30	30
Ae (See diagram)	20	20	20	20	20	20	20	20	20	20
Ld (See diagram)	30	30	30	30	30	30	30	30	30	30
Ad (See diagram)	35	30	30	25	25	15	15	10	10	10
ØA	85	105	118	148	178	210	260	322	370	370
ØC	48	63	73	100	127	147	199	248	296	296
ØD	165	185	200	220	250	285	340	405	460	460
ØK	125	145	160	180	210	240	295	355	410	410
n x Ød	4x18	4x18	8x18	8x18	8x18	8x22	12x22	12x26	12x26	12x26
Kg	5.5	7.0	8.0	9.0	11.0	13.0	19.0	27.0	33.0	33.0

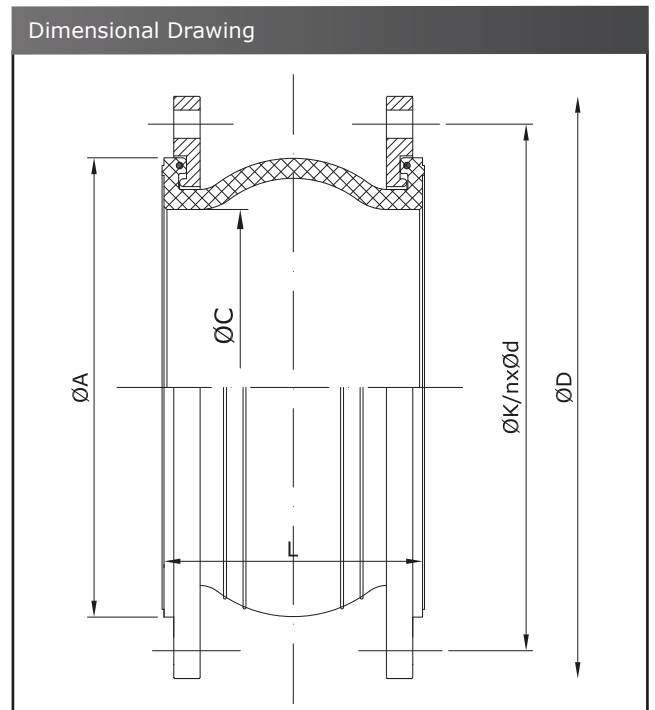
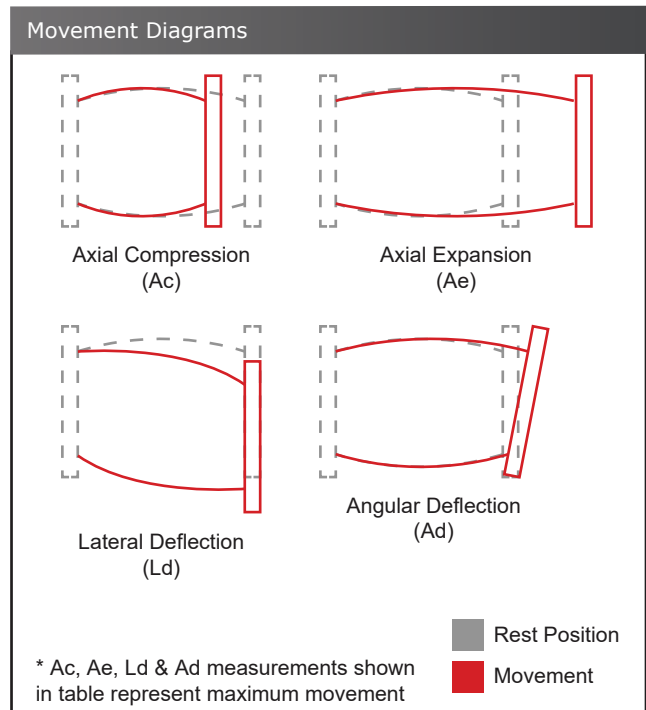

All information is sourced from our manufacturer's data and is intended for guidance only - we can accept no liability for changes, omissions or errors.

Last updated 01/08/2023