

Stainless Steel 3 Way Ball Valve

LV 6400 T & LV 6411 L

ISO 5211 for Direct Mount, Screwed BSPT, Reduced Bore, Stainless Steel
Body, Ball & Stem, PTFE Seats & Seals.



Pressure / Temperature Specifications	
Pressure	PN63
Temperature	-20°C to 180°C

Material Specifications	
1. Body	ASTM A351 CF8M Stainless Steel
2. Ball	ASTM A351 CF8M Stainless Steel
3. Stem	AISI 316 Stainless Steel
4. End Cap	ASTM A351 CF8M Stainless Steel
5. Body Seal	PTFE
6. Ball Seat	RPTFE
7. Thrust Washer	RPTFE
8. Stem Packing	RPTFE
9. Gland Nut	AISI 304 Stainless Steel
10. Handle	AISI 304 Stainless Steel
11. Handle Sleeve	Plastic
12. Stem Nut	AISI 304 Stainless Steel
13. Handle Washer	AISI 304 Stainless Steel
14. Handle Nut	AISI 304 Stainless Steel
15. Locking Pad	AISI 304 Stainless Steel
16. Belleville Washer	AISI 304 CSP Stainless Steel
17. Stop Washer	AISI 304 Stainless Steel
18. O-ring	Viton
19. Packing Follower	PTFE + 25% Glass Fibre

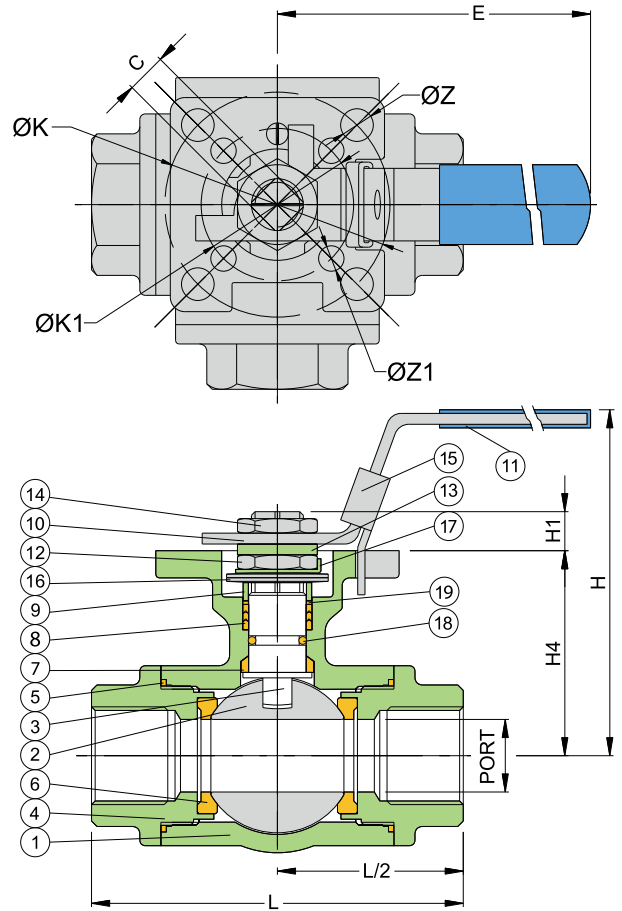

Dimensions													
Size	PORT	L	E	H	H1	H4	C	$\varnothing K1$	$\varnothing K$	Z1	Z	Nm*	
1/4"	11.0	68.0	112.0	71.5	9.0	38.2	9.0	F03	F04	6.0	6.0	7.5	
3/8"	11.0	68.0	112.0	71.5	9.0	38.2	9.0	F03	F04	6.0	6.0	7.5	
1/2"	12.7	68.0	112.0	71.5	9.0	38.2	9.0	F03	F04	6.0	6.0	7.5	
3/4"	16.0	86.6	112.0	74.0	9.0	45.2	9.0	F03	F04	6.0	6.0	11.0	
1"	20.0	90.0	136.5	90.0	11.0	56.5	11.0	F04	F05	6.0	7.0	14.0	
1 1/4"	25.0	105.0	188.0	95.1	11.0	61.9	11.0	F04	F05	6.0	7.0	21.0	
1 1/2"	32.0	118.0	197.5	99.3	14.0	78.3	14.0	F05	F07	7.0	9.0	27.0	
2"	38.1	138.0	197.5	108.0	14.0	87.4	14.0	F05	F07	7.0	9.0	50.0	
2 1/2"	48.0	185.0	210.5	140.0	17.0	78.3	17.0	F07	F10	9.0	11.0	65.0	
3"	65.0	205.0	245.5	150.0	17.0	87.4	17.0	F07	F10	9.0	11.0	80.0	

* Without Safety