

Cast Iron Gate Valve - Flanged PN16 - Quick Closing

LV 5119

Flanged PN16, EN GJL 250 Body, Cast Bronze Seat, Brass Stem, Inside Screw, Quick Closing Lever, EN558-1 Face to Face.



Pressure / Temperature Specifications	
Pressure	PN10
Temperature	-10°C to 150°C

Materials		
1.	Fork	754-S GM Cast Brass
2.	Packing Gland	EN GJL 250 Cast Iron
3.	Packing	PTFE
4.	Stuffing Box	EN GJL 250 Cast Iron
5.	Gasket	Fasit 205
6.	Stem	CW 614 N Brass
7.	Bonnet	EN GJL 250 Cast Iron
8.	Gasket	Fasit 205
9.	Motherscrew	754-S GM Cast Brass
10.	Wedge 2" to 4"	Cast Bronze
10.	Wedge 5" to 12"	EN GJL 250 Cast Iron
11.	Seats	Cast Bronze
12.	Body	EN GJL 250 Cast Iron
13.	Nut	Zinc-Plated 8.8 Carbon Steel
14.	Screw	Zinc-Plated 8.8 Carbon Steel
15.	Tie Rod	Zinc-Plated 8.8 Carbon Steel
16.	Lever	Carbon Steel
17.	Pin	Carbon Steel

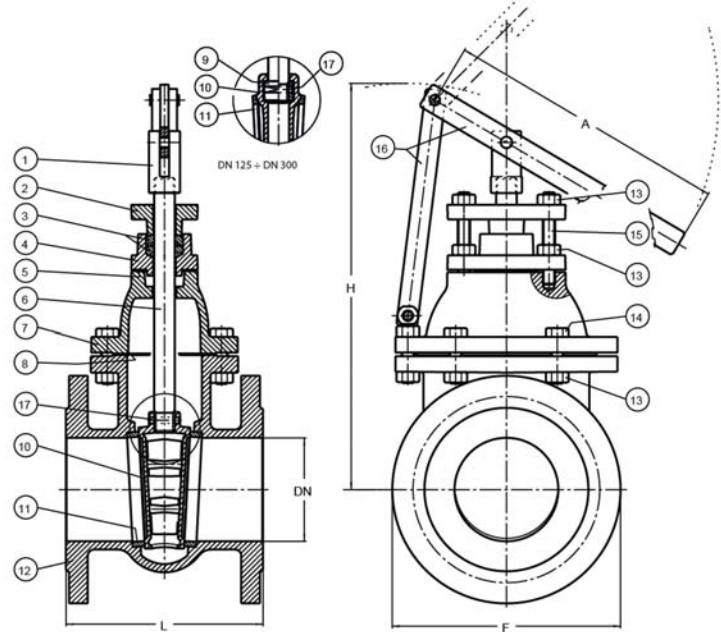

Dimensions						
DN	F	L	H	A	Kvs	Kg
2"	165	150	280	283	250	12.0
2½"	185	170	357	341	430	16.0
3"	200	180	365	341	790	18.0
4"	220	190	390	373	1,250	23.0
5"	250	200	478	396	1,960	32.0
6"	285	210	545	433	2,790	42.0
8"	340	230	660	433	2,880	68.0
10"	395	250	770	676	4,306	96.0
12"	445	270	895	685	6,380	130.0