

# Ductile Iron Ball Valve - Flanged PN16 - Direct Mount

LV 5564

ISO 5211 for Direct Mount, Flanged PN16, Ductile Iron Body, Brass Ball & Stem, RPTFE Seat, NBR O-rings, Steel Lever Operated, DIN 3202 F4 Face to Face 1/2" to 6", F5 8" & 10"



## Pressure / Temperature Specifications

Pressure	PN16
Temperature	-10°C to 100°C

1/2" to 6"

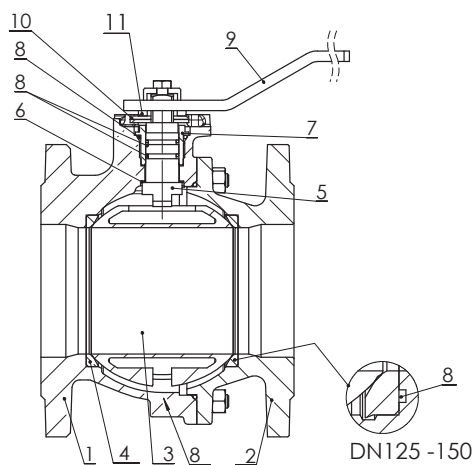

DN125 -150

8"

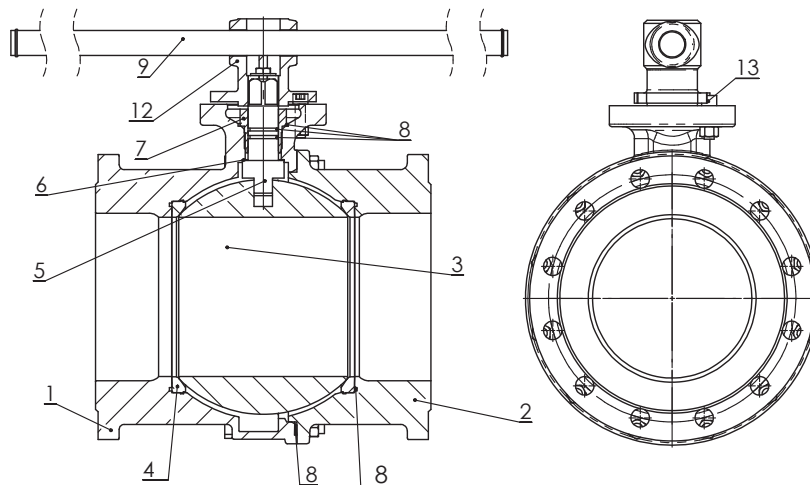

10"

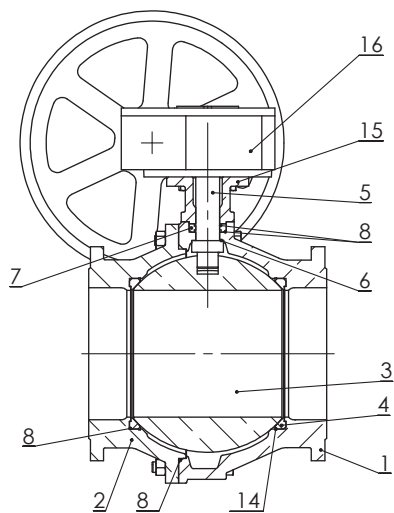

## Material Specifications

1. Body	EN GJS 400-15 Epoxy Coated Ductile Iron
2. Flange	EN GJS 400-15 Epoxy Coated Ductile Iron
3. Ball	CuZn40Pb2 Brass
4. Ball Seat	Reinforced PTFE
5. Stem	Chrome Plated CuZn40Pb2 Brass
6. Sliding Washer	PTFE
7. Ring	Chrome Plated CuZn40Pb2 Brass
8. O-ring	NBR
9. Lever	Epoxy Coated Carbon Steel
10. Stop Plate	Galvanized Carbon Steel
11. Spring Washer	Galvanized Carbon Steel
12. Handle Support	EN GJS 400-15 Epoxy Coated Ductile Iron
13. Handle Stop	Galvanized Carbon Steel
14. Retaining Ring	AISI 302 Stainless Steel
15. Gearbox Bearing	EN GJS 400-15 Epoxy Coated Ductile Iron
16. Gearbox	EN GJS 400-15 Epoxy Coated Ductile Iron

See following page/s for dimensions, headloss & pressure/temp charts

# Ductile Iron Ball Valve - Flanged PN16 - Direct Mount

LV 5564

1/2" to 6"

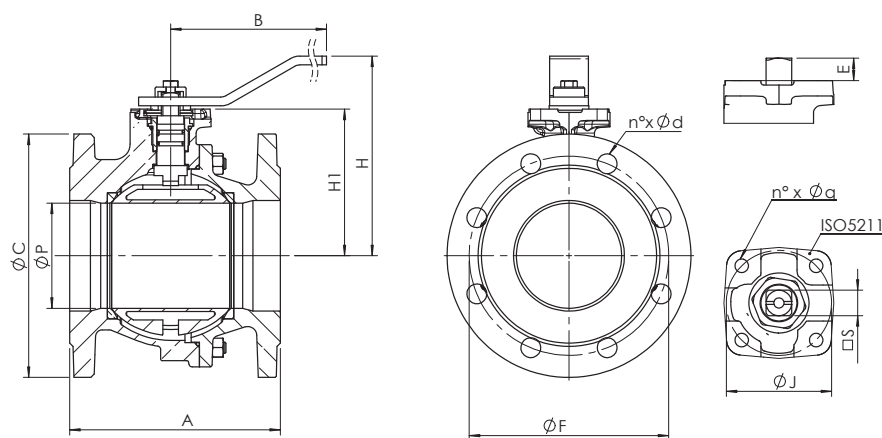

8"

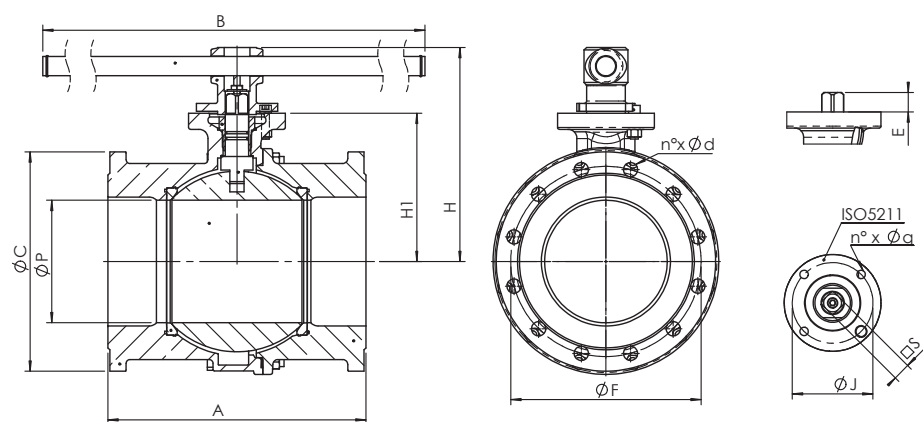

## Dimensions

DN	P	A	H	H1	B	C	F	n x d	ISO	J	N x q	E	S	Nm*	Kv	Kg
1/2"	15	115	160	50.5	84	95	65	4x14	F04	42	4x6	9.5	9	15	22.3	2.6
3/4"	20	120	160	52	84	105	75	4x14	F04	42	4x6	9.5	9	15	47.7	3.3
1"	25	125	170	59	96	115	85	4x14	F04	42	4x6	11	11	18	83.5	4.2
1 1/4"	32	130	170	64	101	140	100	4x18	F04	42	4x6	11	11	18	150.4	5.8
1 1/2"	40	140	125	78.5	230	150	110	4x18	F05	50	4x7	13.5	14	18	255.0	7.5
2"	50	150	135	87	230	165	125	4x18	F05	50	4x7	13.5	14	20	435.0	9.0
2 1/2"	63	170	143	95	230	185	145	4x18	F05	50	4x7	13.5	14	40	672.0	10.5
3"	76	180	165	118	280	200	160	8x18	F07	70	4x9	15	17	70	947.0	15.5
4"	95	190	180	132.5	360	220	180	8x18	F07	70	4x9	15	17	100	1508.0	18.5
5"	120	200	225	165	520	250	210	8x18	F10	102	4x11	21	22	180	2633.0	28.0
6"	145	210	243	182.5	520	285	240	8x22	F10	102	4x11	21	22	250	4261.0	38.5
8"	190	400	320	230	1000	340	295	8x22	F12	125	4x13	27	27	600	5957.0	93.0

\*In order to choose the correct actuator, we recommend multiplying the Nm figure by a safety factor of 1.5

See following page/s for 10" dimensions, headloss & pressure/temp charts

# Ductile Iron Ball Valve - Flanged PN16 - Direct Mount

LV 5564

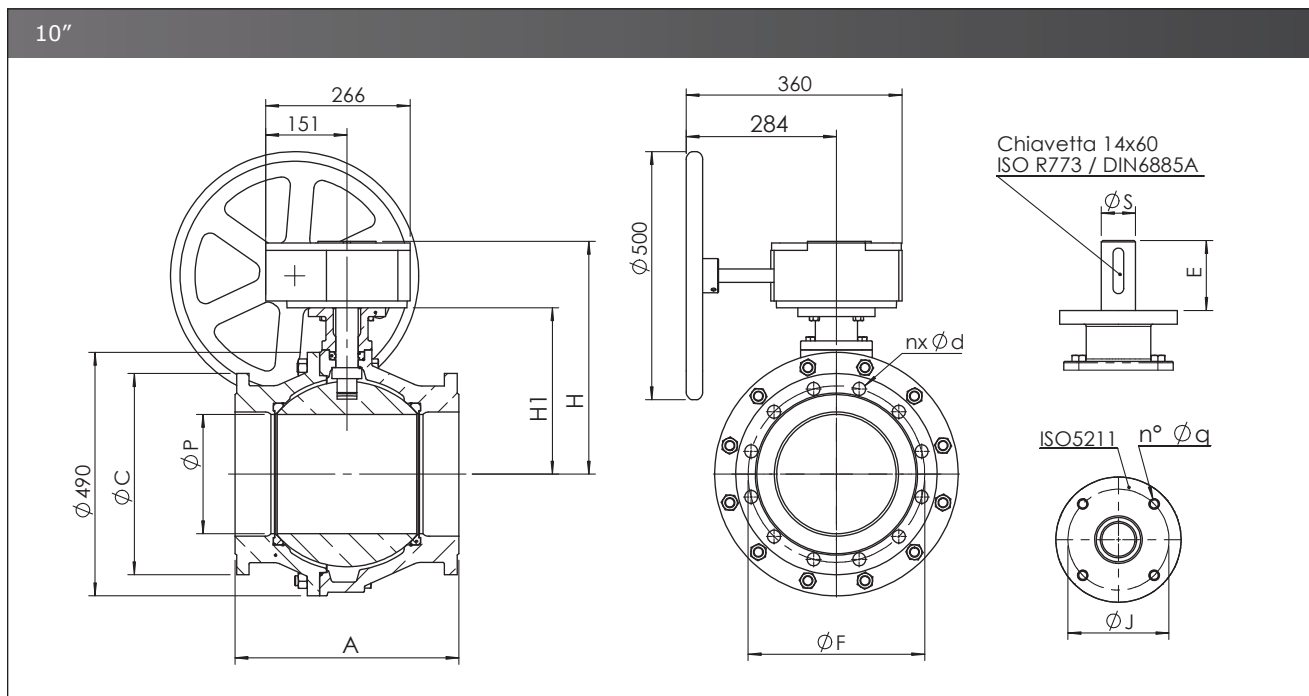

## Dimensions

DN	P	A	H	H1	C	F	n x d	ISO	J	N x q	E	S	Nm*	Kv	Kg
10"	240	450	448	335	405	355	8x26	F12	125	4x13	92	45	2000	10510	180.0

\*In order to choose the correct actuator, we recommend multiplying the Nm figure by a safety factor of 1.5

# Ductile Iron Ball Valve - Flanged PN16 - Direct Mount

LV 5564

Headloss Chart

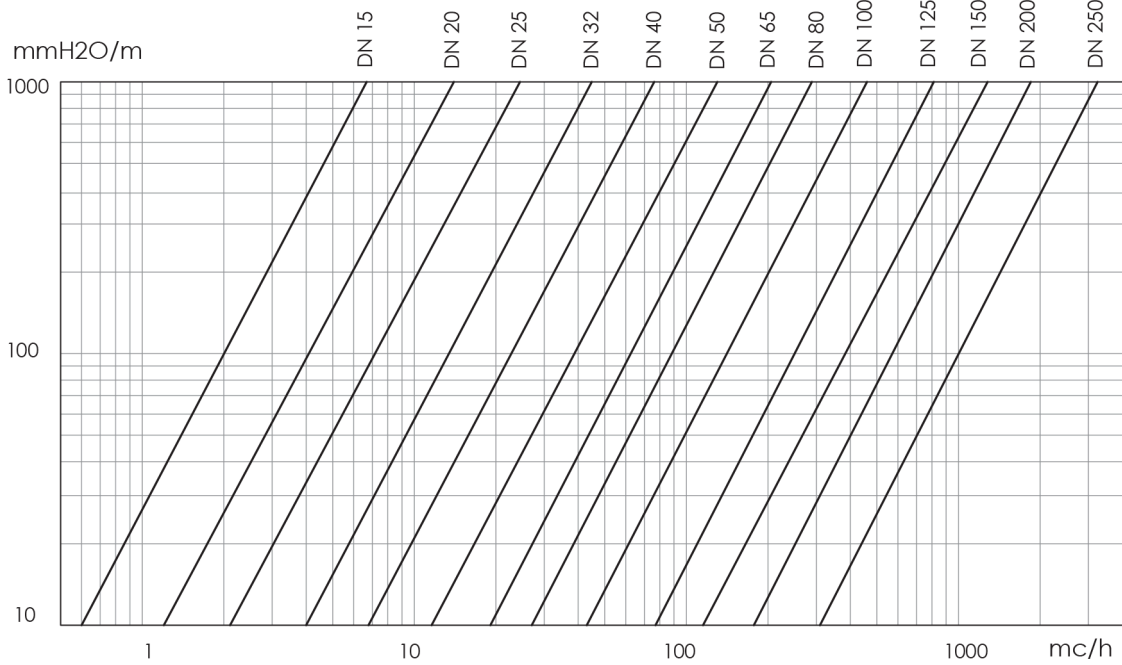

Pressure/Temperature Chart

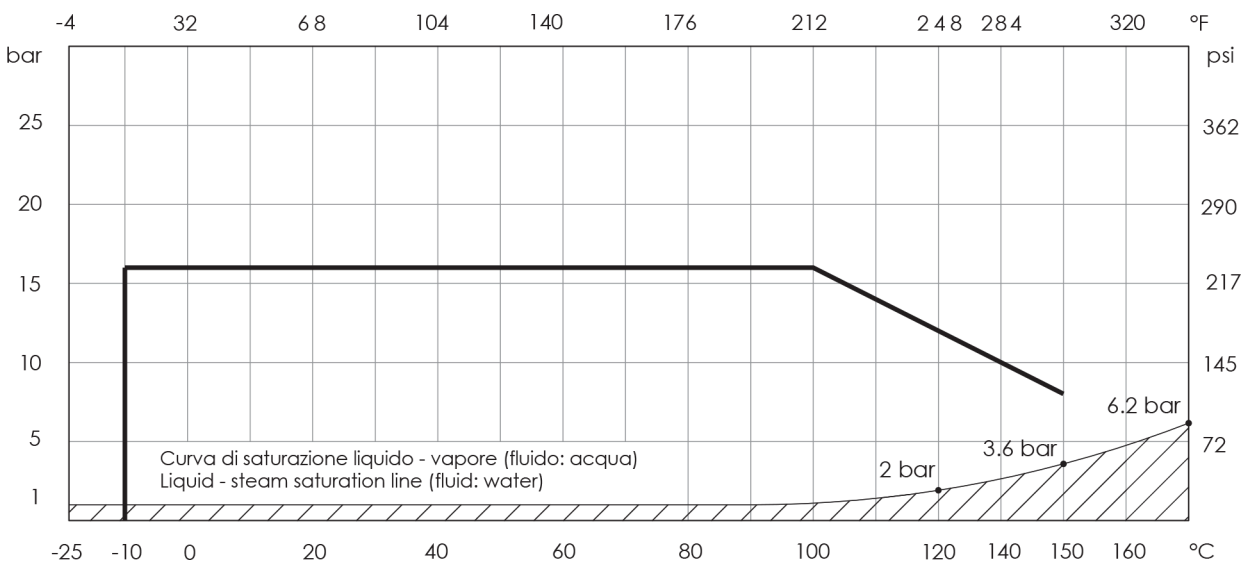

Note: This range is not suitable for steam. Do not use when the pressure & temperature are below the liquid/steam saturation line (hatched area)