

## Gearbox

**Features:** Manual operated quarter-turn gearbox for ball and butterfly valve.

GJL 250 cast iron body with epoxy coating. Sealed to IP67.

**Optional accessories:** Position indicator, padlocking, limit switchbox, chain driver, stem extension.

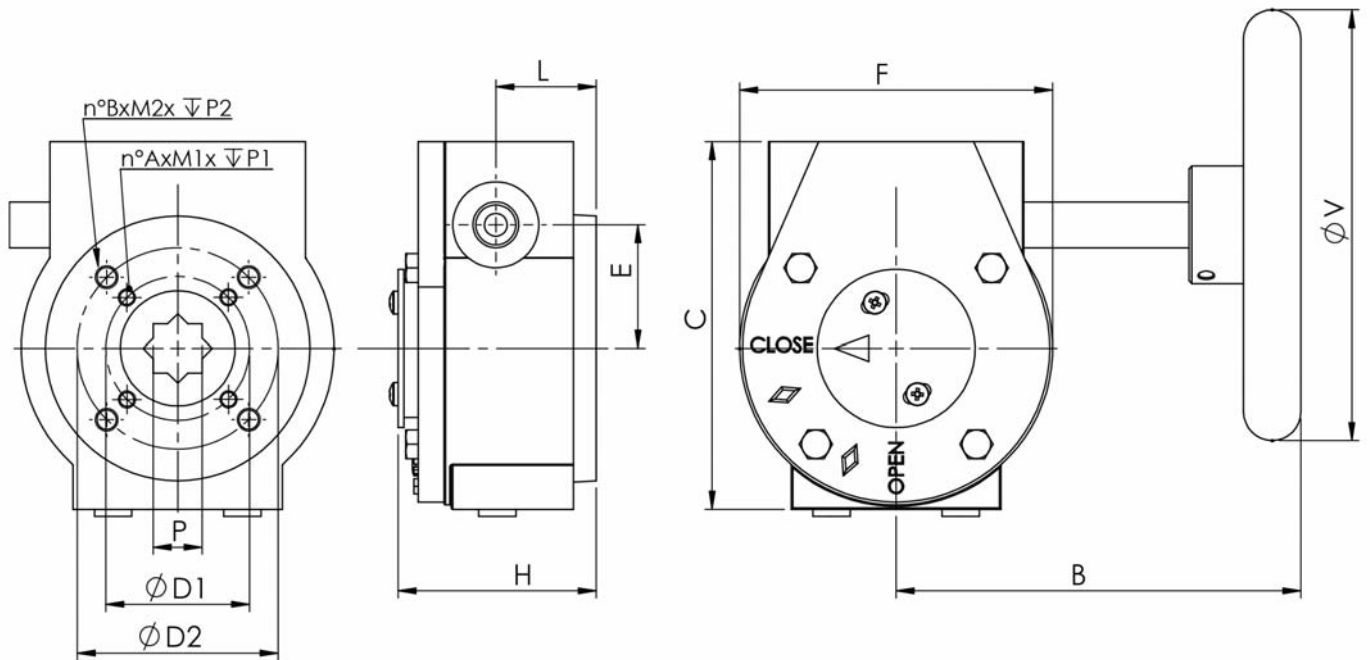

Mod.	Max Torque	ISO5211	D1	N°AxM1x∇P1*	D2	N°AxM2x∇P2*
RM.0250	250	F05-F07	50	4xM6x10	70	4xM8x16
RM.7250	750	F10-F12	102	4xM8x16**	125	4xM10x16**
RM.1200	1200	F12	125	4xM12x21		

Mod.	Kg	B	C	E	F	H	L	V
RM.0250	6	170	130	45	110	65	38	150
RM.7250	14	215	176	63	155	78	42	300
RM.1200	16	226	195	81	170	80	41	300

Dimensions shown in mm

\* Number of Holes x Thread x Thread Depth

\*\* Do not comply with ISO5211 Standard

## Gearbox - Installation Instructions

### 1. Preface

RM Series Gearboxes are quarter turn gearboxes intended for manually operated ball and butterfly valves.

#### 1.1. Technical Data

Connection data and allowable torques are as follows:

Type	Max Torque (Nm)		Connection		
	Output	Input	Size	Drilling*	Bore***
RM.0250	250	21	2" to 6"	4 x M6 x 10 / 4 x M8 x 16	P 17
RM.0750	750	50	8"	4 x M8 x 16 / 4 x M10 x 16**	P 22
RM.1200	1200	48	10" to 12"	4 x M12 x 21	P 27

\*: number of holes x thread x thread depth

\*\* : does not comply with ISO5211 standard

\*\*\*: Q= square, P=polygon

#### 1.2 Warnings

- Be sure to read and understand this manual before the installation and use of the gearbox.
- Check that the gearbox is correctly sized for the valve to be operated; do not exceed maximum allowable torques.
  - Installation and operating shall be carried out by trained staff, taking account of local safety regulations.
  - Store in a dry place and protect against dust.

### 2. Installation

1. We recommend to mount the handwheel on the input shaft before assembling the gearbox to the valve. (Fig 1.)

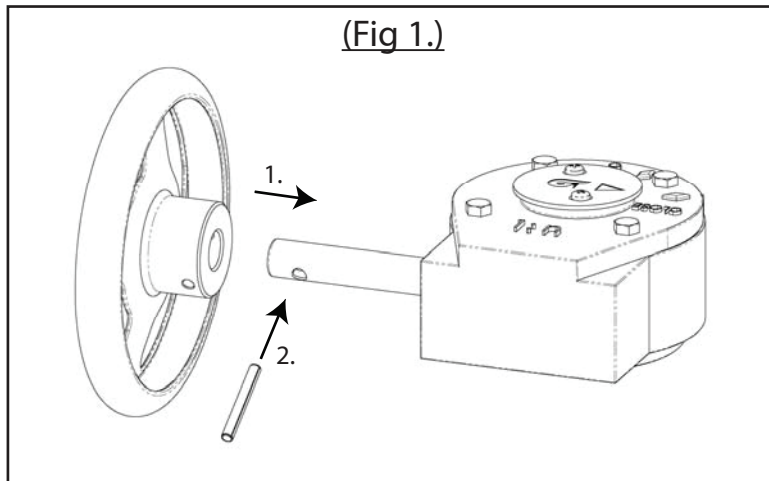

2. Gearbox is delivered in 15% off closed position. Check the fully closed position by turning the handwheel clockwise.
3. Check that bolt circle if the ISO flanges (valve and gearbox) match. Check also that valve stem and gearbox bore match.
4. Make sure the valve is in the closed position. If not, close the valve before continuing.
5. Mount the gearbox on the valve. Fasten with bolts and spring washers. Use bolts of 8.8 quality or better. Thread depth is shown in section 1.1 above. Fasten bolts crosswise to the torque values shown here:

Bolt	M6	M8	M10	M12
Torque (Nm)	9.5	23	46	79

## Gearbox - Installation Instructions

### 3. End stop adjustment

If an adjustment of the closing / opening position is required, do as follows:

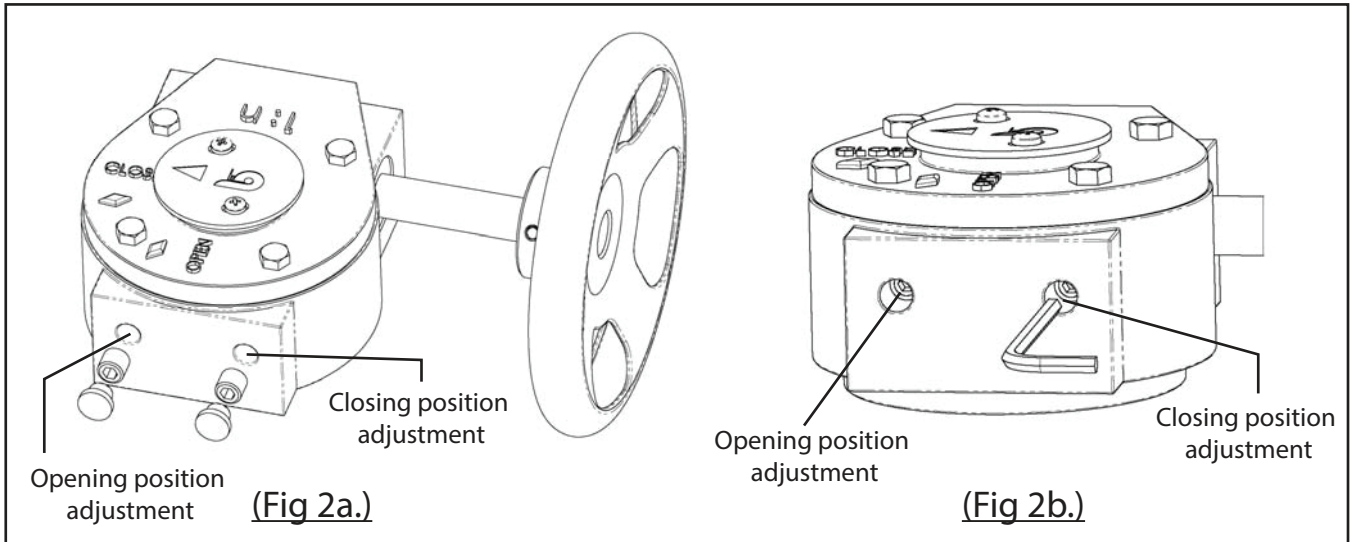

#### 3.1 Closing position adjustment

1. Turn the valve handwheel to reach the gearbox closing position.

2.1. If the fully closed position cannot be achieved, remove protection cap and blocking screw (Fig 2a) and loosen the adjustment set screw with an Allen Key. (Fig 2b.) Turn handwheel clockwise to reach fully closed position. Screw the adjustment set screw until it stops.

2.2. If the fully closed position is overrun, turn the handwheel anti-clockwise to meet the fully closed position. Screw the adjustment set screw until it stops.

3. Screw the block screw until it stops and put the cap back in place.

#### 3.2. Opening position adjustment

4. Turn the handwheel to reach the gearbox opening position.

5.1. If the fully open position cannot be achieved, remove protection cap and blocking screw (Fig 2a) and loosen the adjustment set screw with an Allen Key. (Fig 2b.) Turn handwheel anti-clockwise to reach fully open position. Screw the adjustment set screw until it stops.

2.2. If the fully open position is overrun, turn the handwheel counter clockwise to meet the fully open position. Screw the adjustment set screw until it stops.

3. Screw the block screw until it stops and put the cap back in place.

### 4. Operating and Maintenance

- Operating direction: turn clockwise to close, turn anti-clockwise to open. The valve position is indicated by the arrow on the gearbox position indicator.
  - The gearbox is self-braking. No additional fixtures are required to retain the valve position.
  - We recommend you check the bolt between the valve and gearbox for tightness six months after commissioning.
  - If the gearbox is seldom operated we recommend you perform a test run every six months.